

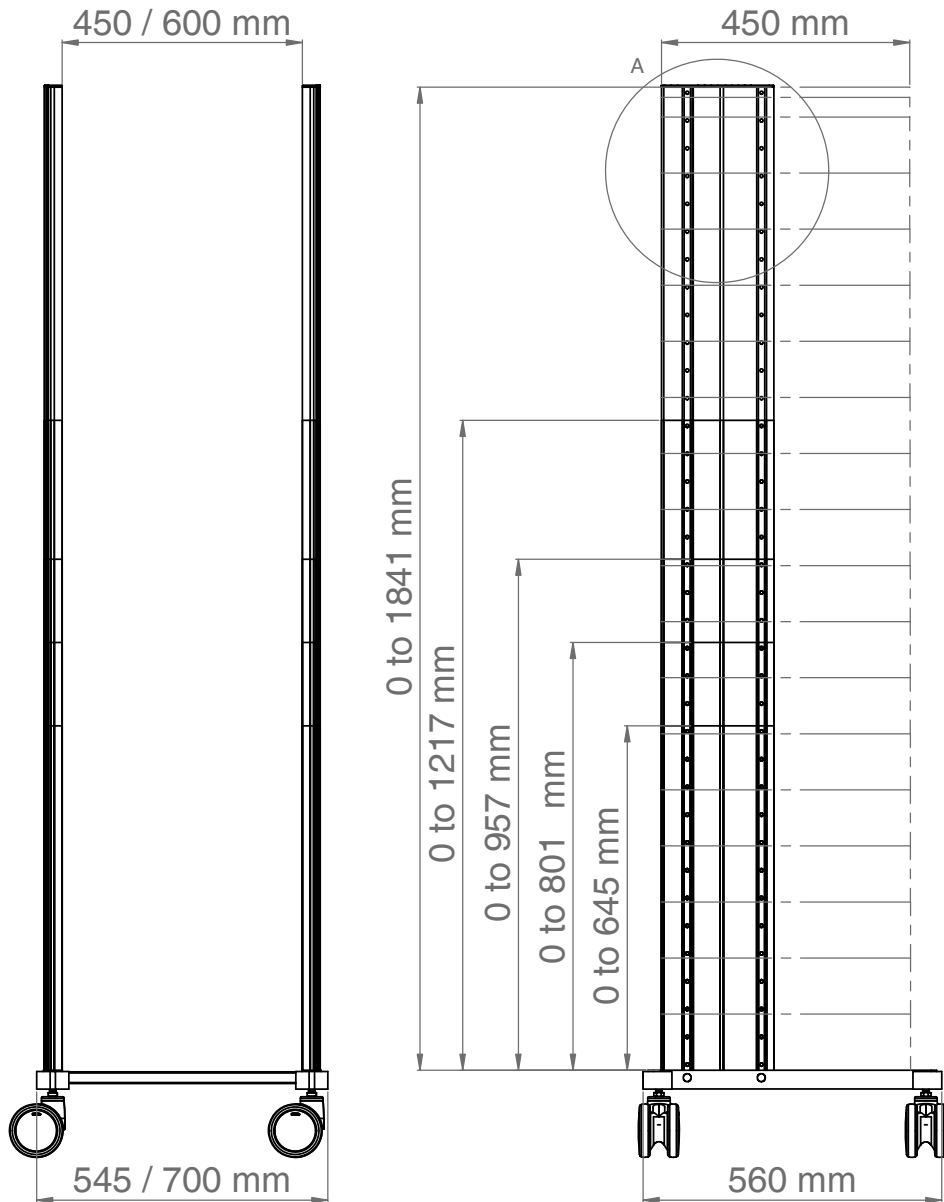

Planning sketch for individual height of carrier profiles, in 52 mm steps



swingo wood/plastic swingo-clinic metal

Example: Installation

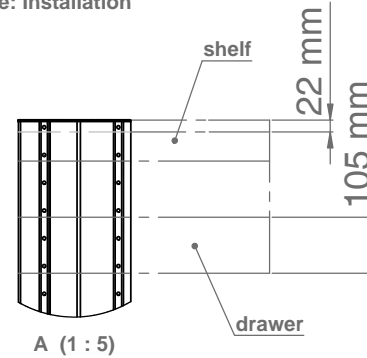

Colour of decorative strips and push handles

grey
blue
yellow

	Height of profile	
	standard	variable
645 mm <input type="checkbox"/>	0 - 636 mm <input type="checkbox"/>	
801 mm <input type="checkbox"/>	0 - 1217 mm <input type="checkbox"/>	
957 mm <input type="checkbox"/>	0 - 1841 mm <input type="checkbox"/>	
1217 mm <input type="checkbox"/>		

(Grids = 52 mm)

For optimal stability, each cart with a profile height up from 957 mm has to be equipped with one horizontal arm, ref. no. 16555 or ref. no. 16554

Chassis / castors / load capacity:

Chassis / castors / load capacity:	45	60
Cart	<input type="checkbox"/>	<input type="checkbox"/>
castors Ø100	<input type="checkbox"/>	<input type="checkbox"/>
(swingo up to 120 kg) (swingo-clinic up to 130 kg)		with 2 brakes <input type="checkbox"/>
Cart	45 <input type="checkbox"/>	60 <input type="checkbox"/>
castors Ø125, 2 lockable	<input type="checkbox"/>	<input type="checkbox"/>
(swingo up to 120 kg) (swingo-clinic up to 130 kg)		
Cart		60 <input type="checkbox"/>
castors Ø150, 2 lockable		<input type="checkbox"/>
(swingo up to 120 kg) (swingo-clinic up to 250 kg)		
Cart	45 <input type="checkbox"/>	60 <input type="checkbox"/>
castors Ø100	<input type="checkbox"/>	<input type="checkbox"/>
with base plate 300 mm deep (swingo up to 120 kg) (swingo-clinic up to 130 kg)		with 2 brakes <input type="checkbox"/>
Cart		60 <input type="checkbox"/>
castors Ø150, 2 lockable		<input type="checkbox"/>
extended to the rear, electrically conductive (swingo up to 120 kg) (swingo-clinic up to 250 kg)		
4 electrically conductive castors		<input type="checkbox"/>