

# Planning sketch for your toro cart

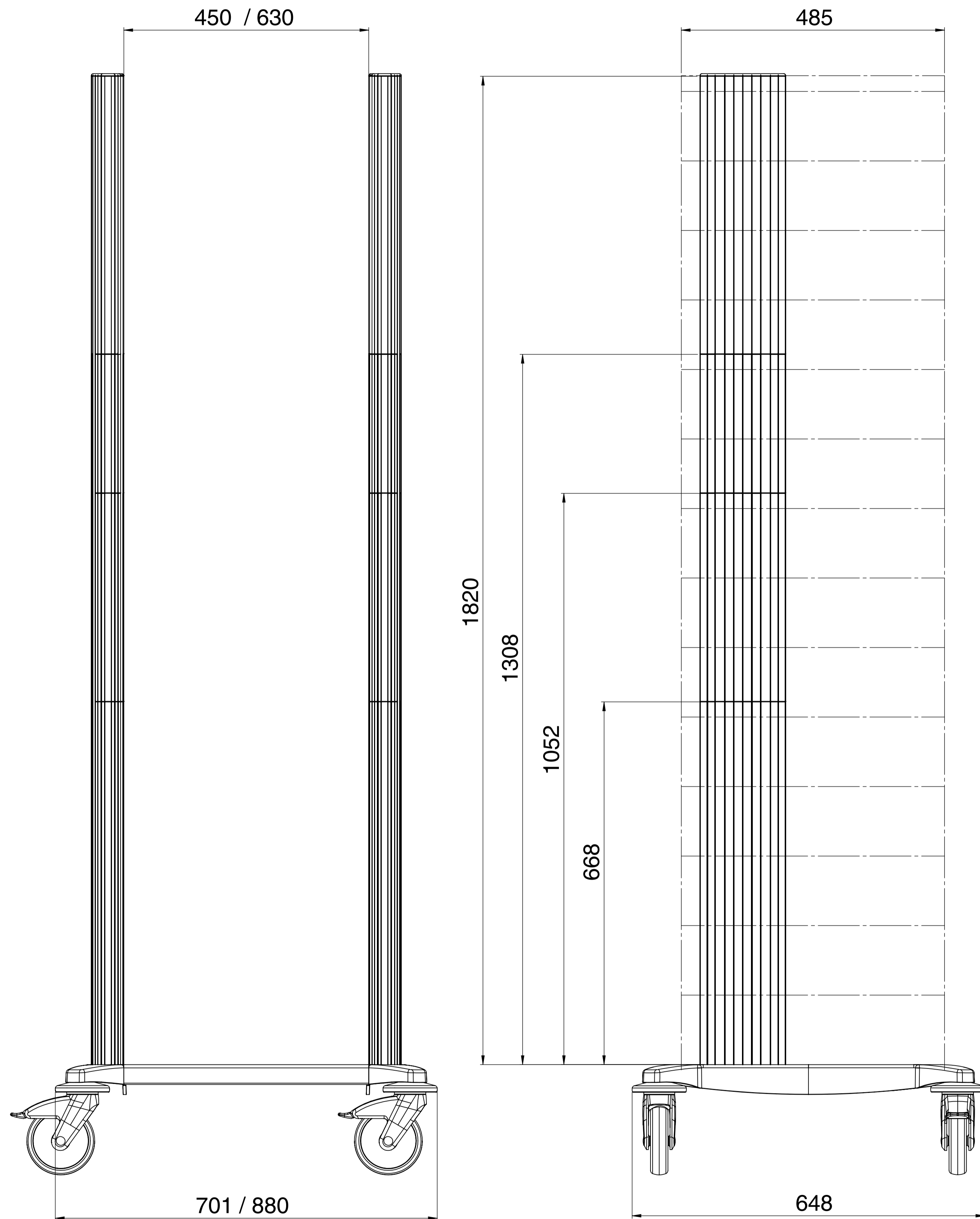

## Cable duct horizontal arm

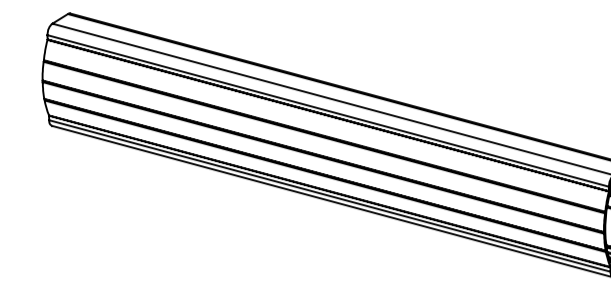

toro

45

63



## Horizontal arm

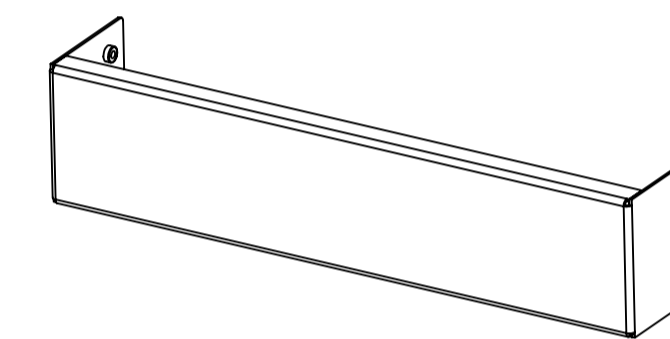

toro

45

63

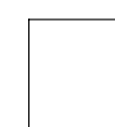

Notes:

## Chassis

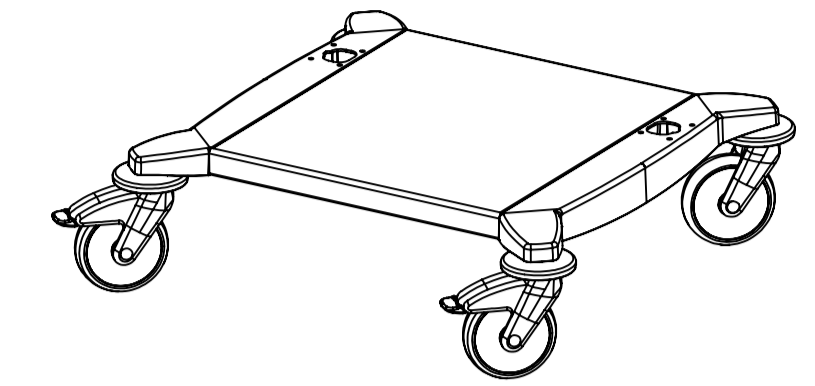

toro

45

63



Castors Ø125 mm  
Load capacity  
up to 130 kg

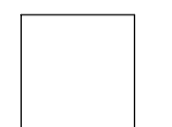

Castors Ø150 mm  
Load capacity  
up to 250 kg

Extra charge for 4  
electrically conductive castors

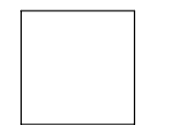

## Height of the carrier column

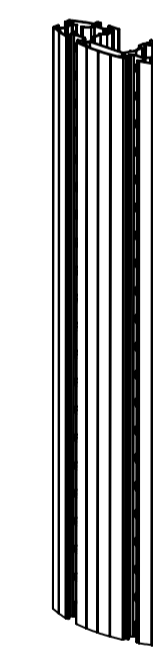

standard

varianle

668 mm



0 - 636 mm



1052 mm



700 - 1020 mm



1308 mm



1084 - 1266 mm



1340 - 1820 mm



(grids = 32 mm)

For optimal stability each toro cart with  
carrier unit up from 668 mm has to be  
equipped with one horizontal arm or  
with a cable duct horizontal arm