

# Planungsskizze für Ihren toro-Wagen

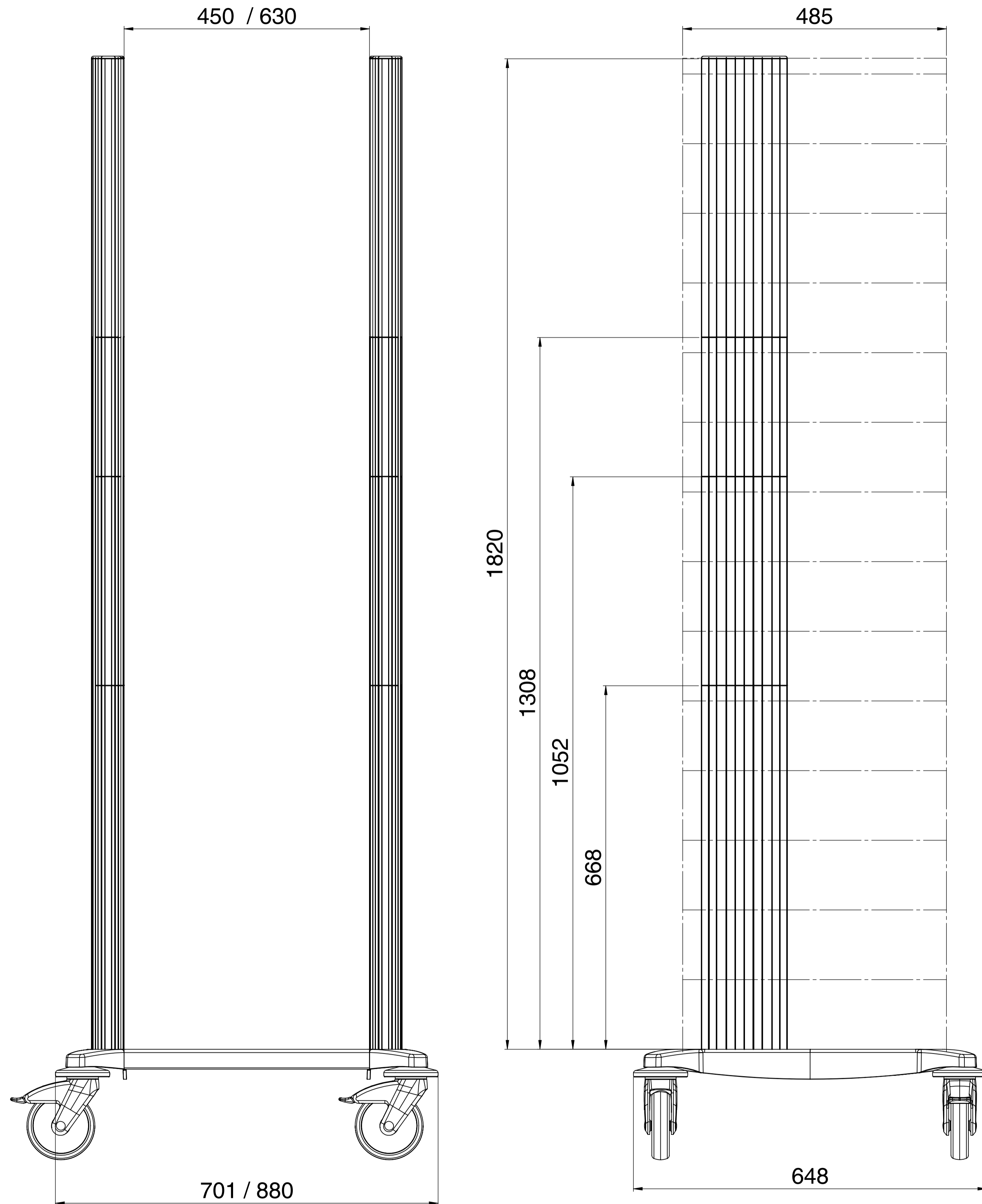

## Kabelkanaltraverse

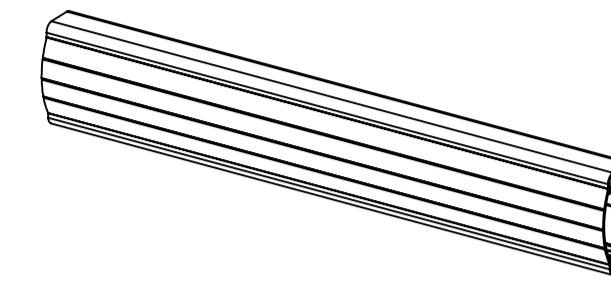

toro

45

63

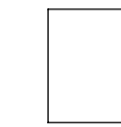
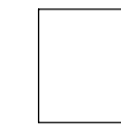

## Quertraverse

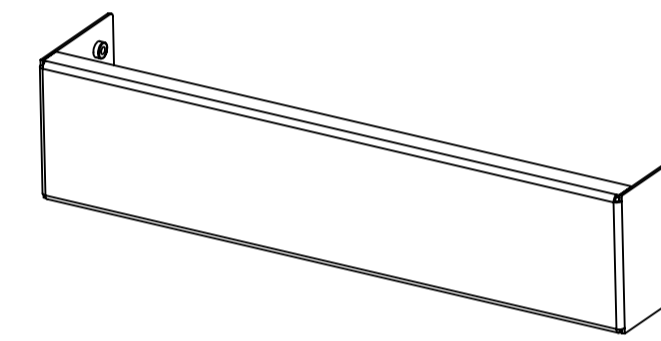

toro

45

63



Bemerkungen:

## Fahrgestell

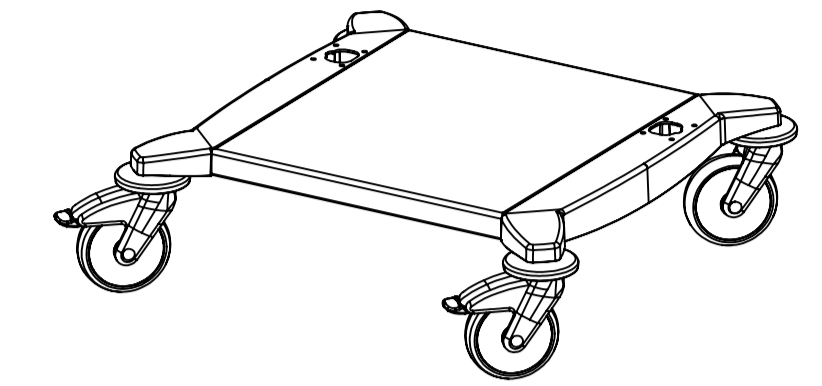

toro

45

63

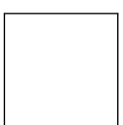
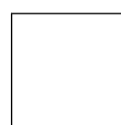

Rollen Ø125 mm  
Belastung bis 130 kg

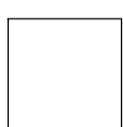

Rollen Ø150 mm  
Belastung bis 250 kg

Aufpreis für 4  
elektrisch leitfähige  
Rollen

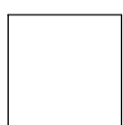

## Höhe Trägerprofil

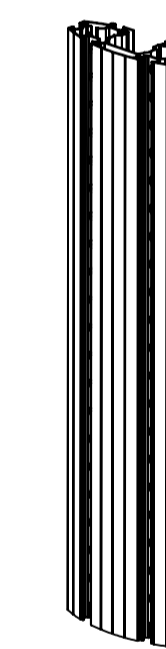

standard

variabel

668 mm



0 - 636 mm



1052 mm



700 - 1020 mm



1308 mm



1084 - 1266 mm



1340 - 1820 mm



(Raster = 32 mm)

Bei einer Profilhöhe ab 668 mm  
ist aus Stabilitätsgründen eine  
Quertraverse oder  
Kabelkanaltraverse erforderlich.